

Ensoniq SQ80
Service Manual

Dipl. Inform. Rainer Buchty

November 10, 1999

Abstract

This document is based on the original SQ80 Service Manual, which turned out to be hard to get. I was lucky getting a copy from somebody who sells copies of service manuals for a huge variety of electronic instruments, however, the price of almost US\$25 for just copying is pretty ridiculous, especially if the copies aren't of a very good quality.

So I decided to re-print this manual. All graphics (except the exploded view) were drawn and not scanned, the text was typed since the copy's quality was too poor to make use of OCR software.

I've made a few additions to the original text. To separate this I've written it *[this way]*. And remember: Whenever the text reads something like "send back to Ensoniq" - forget it. Ensoniq has dropped support for ESQ-1 and SQ80 completely.

Contents

1	Important things to know about the SQ80	7
1.1	The keyboard	7
1.2	The disk drive	8
1.3	Ferrite Beads	10
1.4	Main Boards and Shields	10
1.5	Plastic Case	10
2	Troubleshooting Guide	13
2.1	Internal Memory	13
2.1.1	Checking the Power Supply	13
2.2	Transformer and Power Supply Voltage Check Points	14
2.3	Power Supply Measurements	15
2.4	Testing the Power Supply unloaded	16
2.5	Display Self Test Mode	16
2.6	Using Self-Test Mode to Diagnose Keypad/ Display Assembly	18
2.7	SQ80 Test Procedure	19
2.8	Hardware Notes	24
A	Replacing the Main Board	26
B	Replacing the Keypad / Display Board	27
C	Replacing the Keyboard	28
D	Replacing the Power Supply	30
E	Replacing the Transformer	31
F	Replacing the Pitch/Mod Wheel Assembly	32
G	Replacing the Line Filter	33
H	Replacing the Operating System EPROMs	34
I	Replacing the Keyboard (KPC) EPROM	35
J	Replacing the Disk Drive	37
K	Adding a Ferrite Bead	38

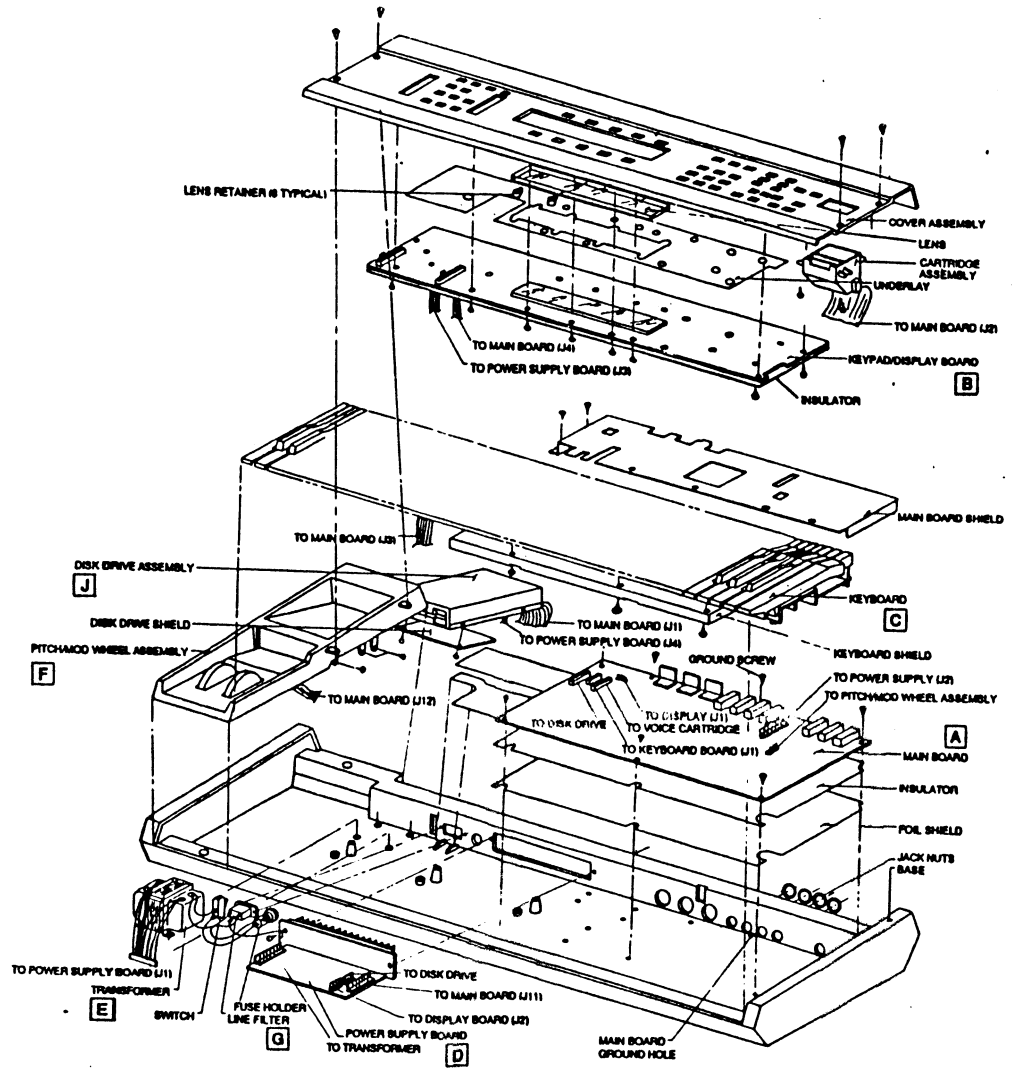

Figure 1: SQ80 Exploded View

Chapter 1

Important things to know about the SQ80

While the SQ80 is similar to the ESQ-1 in many ways, there are some major differences between the two units. *If you don't read any other part of this manual, read this section.* The following information details these differences.

1.1 The keyboard

The poly-pressure keyboard is a complex module which contains its own computer and software. For this reason, when necessary, you will be swapping it out as a whole unit. Display information to the Main Board is processed through the keyboard so what might appear to be a frozen display could instead be a bad keyboard. Also, what might appear to be a bad keyboard (display stuck at calibration page) might instead be caused by scrambled RAM (in which case the memory needs to be dumped). For more detailed debugging hints, see the flow chart on page 12 and hardware notes on page 24. Be sure to have the serial number of the unit ready when ordering a replacement keyboard.

Weights

The weights inside the white keys of some early units have tended to fall out and roll about in the case. If that happens, simply glue the weight back into the key with super glue gel.

Cables

When reconnection the keyboard cable to the Main Board, make sure that the red line on the cable is on pin 1 and that the cable is not mis-pinned. If the cable *is* mis-pinned or backwards, fuses F3 and F4 will blow and cause the display to come up blank. Note that if either fuse blows, you will need to replace both fuses, as one will blow the other.

Shields

If the keyboard you are replacing has a keyboard shield on the bottom (see figure for location) and the replacement keyboard does not, remove

the shield from the old keyboard and install it on the new one. For more detailed instructions see **Appendix C**.

Software

The keyboard has its own operating system EPROM (KPC) which is located on the PC board on the bottom of the keyboard. When you hold down the RECORD button and press the MASTER button you will see:

ENSONIQ SQ-80 SYNTHESIZER/SEQUENCER
SOFTWARE VERSION X.XX - YYY

X.XX indicates the main operating system version, YYY indicates the keyboard operating system. Units with serial numbers less than 500200 may have a keyboard operating system version lower than 150. If this is the case, get the latest version and replace the EPROM as described in **Appendix I**.

The latest software versions are 1.80 for the main operating system and 150 for the keyboard operating system.

1.2 The disk drive

While the SQ80 disk drive is similar to the one used in the DSK-1, its major difference is that it is double-sided. Two different drives have been used in the SQ80:

SQ80 Serial #	Voltage	Drive	Part No.	Distinguishing Feature
500001-500630	220V/ 240V	Panasonic JU-364	8622999492	Red LED drive light, no door
500630-latest	220V/ 240V	Sony 63W-00D	9722000501	Yellow LED drive light, door

Important difference between the Sony and Panasonic drives:

The Panasonic JU-364 and the Sony 63W-00D use different 34-pin ribbon cables. This is due to the fact that the pin out on the Sony drive is reversed from that of the Panasonic. It is therefore important to note the serial number of the unit and to have this information handy when ordering a replacement drive. When possible, install an identical replacement drive. This will avoid you having to replace the cable as well.

Ensoniq plans to replace the current SONY64W-00D disk drive with a Panasonic JU-253 (P/N 9722000601), like the JU-364. This will be effected on units approx. s/n 501770 and up. The new drive is distinguished by a red LED drive light. Unlike the JU-364, however, there is a door over the drive opening. The 34-pin ribbon cable used with the JU-253 is the same one that is used with the Sony 64W-00D.

Mounting holes

The wheel cover assembly has three sets of standoffs to mount the disk drive (see figure). This allows the use of both Sony and Panasonic disk drives. The Panasonic uses the first and second standoffs for its mounting holes (counting from the front of the wheel cover) and the Sony uses the first and the third. For more details on replacing the disk drive, see **Appendix J**.

Transporting a unit

Some of the units may be shipped with a protective plastic yellow sheet inserted in the disk drive.

You must remove this sheet before powering on the unit.

There is a printed label covering the disk drive on every new unit shipped. This label contains important information concerning the care of the SQ80 disk drive and lists recommendations regarding the treatment of the drive during transport.

To reiterate: **It is not, under any circumstances, recommended to insert of an actual disk during transport nor is it recommended to use a cardboard disk sheet in place of plastic ones.**

Transport the unit only with either a plastic sheet in the drive or nothing in the drive at all.

Please do not ship an SQ80 or replacement disk drive in a box packed with peanuts. If you must, wrap the entire unit in plastic first. These peanuts may cause severe damage to the disk drive, keyboard, or cartridge port.

What diskettes to use

It is very important to use double-sided, double-density 3.5" micro-floppy disks. The SQ80 writes information to every track on a disk, so it is imperative that the disk be of superior quality and certified for double-sided use. *[Since double-density disks are hard to get nowadays: Yes, it is ok to use high-density disks instead.]*

Testing the disk drive

The best way to test the disk drive is by formatting a disk. When a disk is formatted, the SQ80 reads and writes every track on that disk. If the formatting attempt fails, it is likely that the disk itself is faulty. Always try formatting another blank disk before determining that the disk drive is faulty. Unlike many computer systems, the SQ80 does not automatically discard bad sector. The entire disk must be good for successful formatting.

The disk drive shield

You will find that there is a metal plate located on the bottom of the disk drive (see figure). The function of this plate is to keep the 34-pin ribbon cable from interfering with the disk drive motor. When replacing the disk drive, it is important to transfer this metal plate to the new drive. The

plate is attached with two screws and accompanying star washers. This plate must be installed to ensure proper operation of the drive.

1.3 Ferrite Beads

On later units, a ferrite bead was added to the wires from the transformer to the power supply to prevent possible memory loss on power down. This ferrite bead should be added to any earlier unit that seems to have a problem with memory loss. See **Appendix K** for more details on how to install this ferrite bead.

On units with approx. s/n 500890 and higher, the ferrite bead is already installed in the factory.

1.4 Main Boards and Shields

Main Boards

There are two versions of the main board used in the SQ80. When you are swapping a main board, it is important to complete the replacement with an identical board. You can distinguish the two boards by taking note of the part number which is screened near the center of the board:

- Part number 4090008001 needs main board shield and keyboard shield
- Part number 4090008002 does not need shields

On units with approx. s/n 500890 and higher, main board 4090008002 is used. If a unit has shields, make sure to put them back in. If the unit does not have shields, do not add them.

Shields

The main board shield and the keyboard shield are shown in **figure .** In some units, these shields are attached using tinnerman clips with the screws. Be aware that these clips may fall off when disassembling a unit. Don't lose them.

Ground wires

On some earlier units, a ground wire was attached to the ground square on the main board, which in turn was attached to the metal main board shield. This wire ensured a good ground in the event that the main board ground screw hole was stripped. If a ground wire is present, you must feed the spade lug end of the ground wire through the opening in the metal main board shield and install it onto the screw directly across from the opening in the shield.

1.5 Plastic Case

Avoid stripping screws. Because the structural components (base, control panel, wheel cover, and keyboard support rails) are made of plastic, great

care should be exercised when assembling or disassembling any part of the SQ80.

Avoid over-tightening screws in the plastic case when executing any repair procedure!

When replacing any of the self-tapping screws, it is possible to over-tighten the screws and strip a hole in the case, making it necessary to replace the case or control panel. To keep this from happening, follow these procedures:

1. Before replacing the screw(s), put a drop or two of Loctite, Super Glue Gel, or RTV into the hole.
2. Install the screw, tightening only until the sub-assembly being attached is snug against the case. *Do not tighten the screws any further.* When the glue sets, the screws will hold the sub-assembly tightly in place.

Ground insert

Initially, all screw holes in the case used self-tapping screws. Later, a brass insert was added to the main board ground boss and the ground wire from the main board was eliminated. Be sure to use a machine screw when a brass insert is present.

Lid inserts

Brass inserts were also added to the lid holes to prevent stripping of these holes. Be sure to use machine screws in those units where brass inserts are present.

Do not use a self-tapping screw in a brass insert as this will ruin the insert!

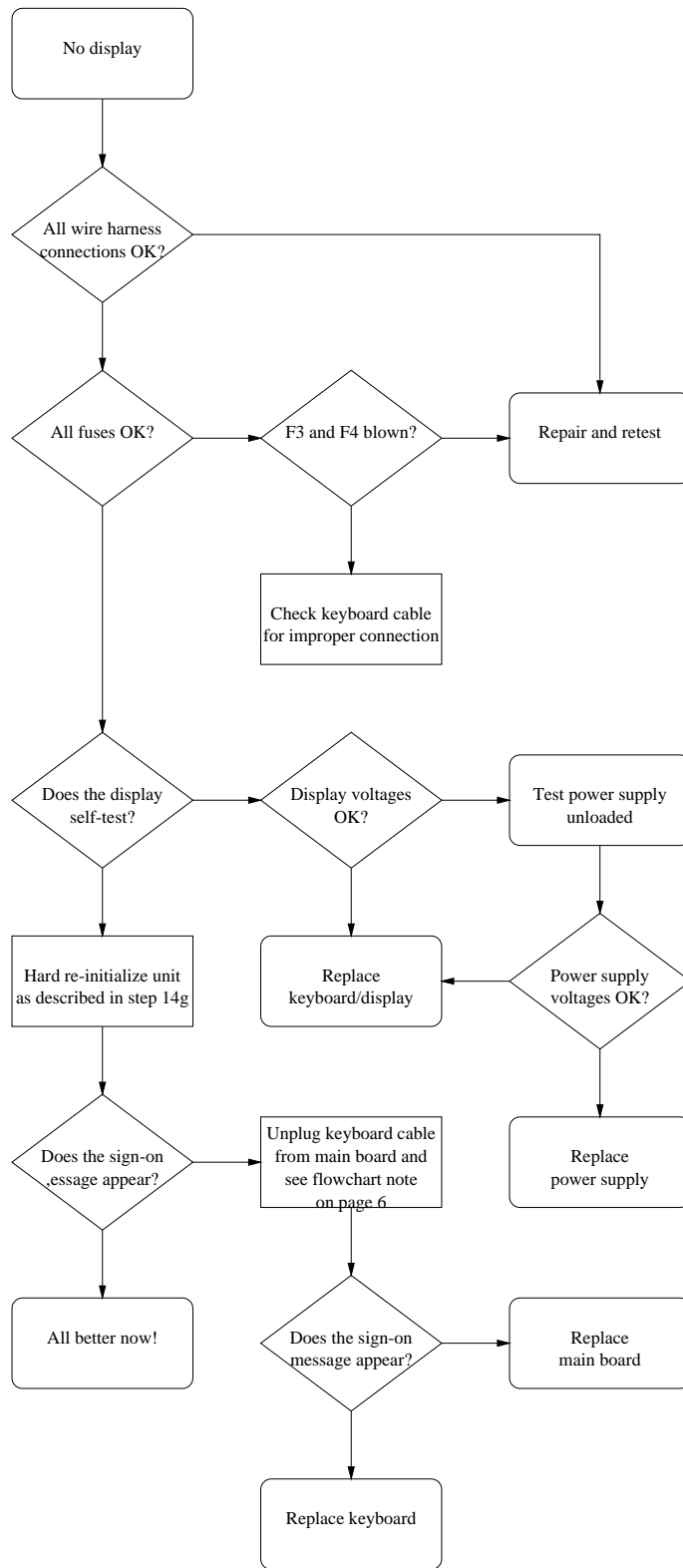

Figure 1.1: Troubleshooting an SQ80 with blank display

Chapter 2

Troubleshooting Guide

Flow chart note

When troubleshooting an SQ80 with a blank display as outlined in the previous flow chart, you may need to determine whether the main board or keyboard is at fault. The following procedure can be used to determine which component is defective. With the power off disconnect the 20-pin keyboard cable from the main board (at J3), then use a clip lead to connect pins 19 and 17 of J3 together. Pins 19 and 17 are the uppermost two of the right tow of pins on J3. Power the SQ80 on. If the sign-on message appears, this indicates that the keyboard is at fault.

If the message does not appear and the main board has been previously hard re-initialized, this indicates a main board problem.

2.1 Internal Memory

A given SQ80 is likely to have program and/or sequence data in its internal memory that is near and important to the owner of that unit. In the event that it becomes necessary to re-initialize the memory during repair it is highly recommended that the internal memory (both programs and sequences) of the unit to be saved to disk before servicing. See the SQ80 Musician's Manual for full instructions on saving program and sequence data.

The SQ80 is essentially a computer with over 80K of memory. It is possible for the SQ80 to become confused if bad data is loaded into its memory. This can result from loading data off of a bad disk or not clearing out the system memory after a MIDI SysEx transfer. If the memory does get scrambled, it will be necessary to re-initialize the system. For this reason, periodic backing up of all program and sequence data and re-initialization is recommended.

2.1.1 Checking the Power Supply

Many SQ80 problems may be related to a faulty power supply, transformer or line filter. You should check these before trouble-shooting the rest of the unit.

Using a 2-mm Allen wrench, remove the four screws securing the front panel and raise the panel. Check to make sure that all the connections are secure and correct. Plug the SQ80 in and turn it on. After the SQ80 has warmed up for five minutes, begin to test the voltages at the points shown in **figures 2.2 and 2.3**. If the voltages vary outside the allowable limits, follow the procedure described under **Testing the Power Supply Unloaded**, before replacing it.

2.2 Transformer and Power Supply Voltage Check Points

The proper AC line voltage for each SQ80 should be printed on the top of the transformer. **Figure 2.2** shows the check points for reading the AC line voltage. **Figure 2.3** shows the connector terminal numbers and correct voltage values for the power supply and transformer. It is normal for line voltage to vary +/-10%.

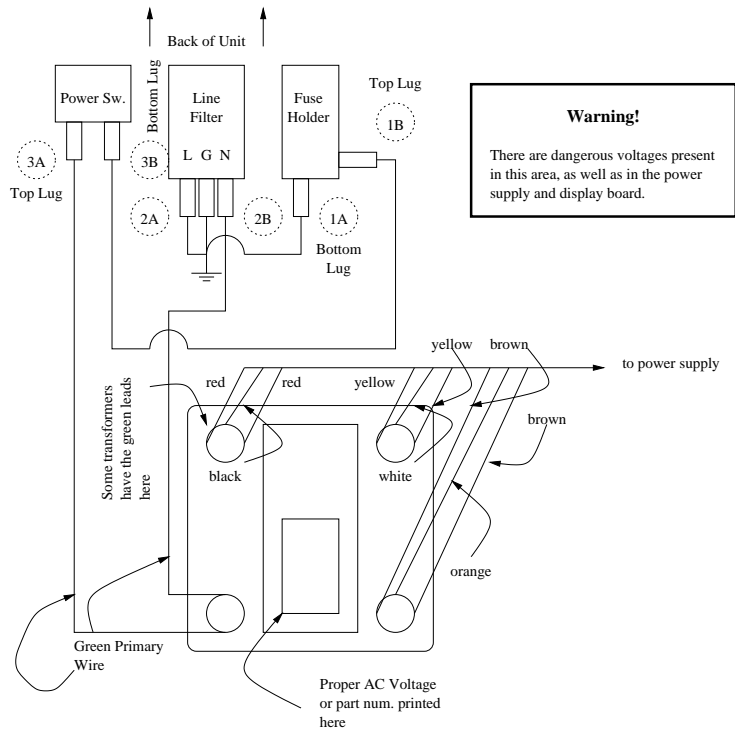

Figure 2.1: AC Line Voltage Check Points

AC line voltage measurements

- With the power switch off, the proper AC line voltage should read from 2B-1A, 2B-2A, 2B-3B.

- With the power switch on, the proper AC line voltage should read from 2B-1A, 2B-1B, 2B-3B, 2B-3A. There should be no voltage across the power switch.

2.3 Power Supply Measurements

On SQ80 systems designed for 220/240 VAC operation, there is only one proper power supply / transformer configuration. This configuration is denoted by both the label on the top of the transformer and the part number silk-screened on the lower left of the power supply PC board. The proper transformer/power supply configuration for the SQ80 is:

Transformer labelled "1450000512 220/240V"
and
power supply labelled "4001008101"

If you suspect a problem with the power supply and the labels on the transformer and power supply do not correspond to the above configuration, contact the Ensoniq customer service dept. for instructions. *[In fact, this is pretty useless nowadays.]*

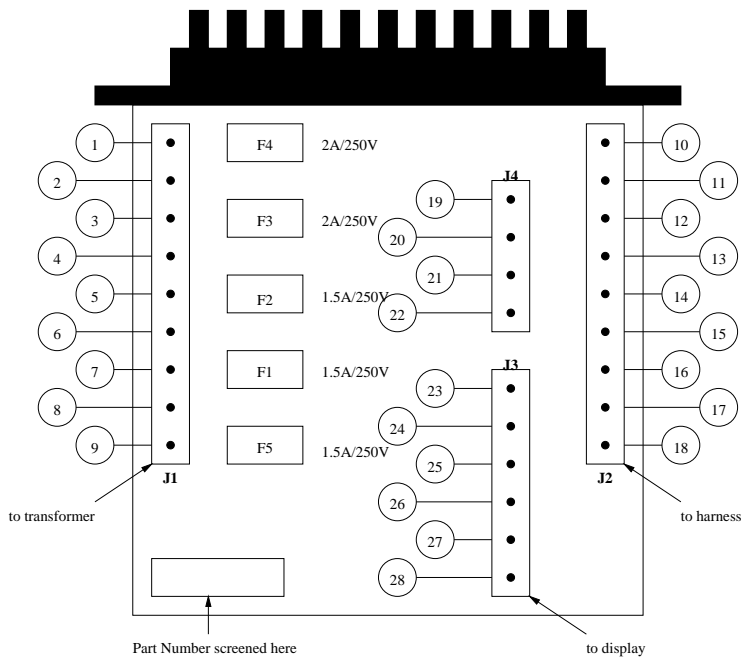

Figure 2.2: Power Supply Voltage Check Points

The following chart lists the voltage ranges for proper operation of each supply (fully loaded) and the appropriate terminals to read across with the voltmeter (refer to **figure 2.3** for terminal locations):

Designation	Terminals		Connector	Range	Unit
	+	-			
Digital Supply	1	3	J1	15 to 19	VAC rms
Analog Supply	4	6	J1	23 to 29.5	VAC rms
Display Filament	7	9	J1	8.5 to 11	VAC rms
+5 Display	11	10	J2	+4.8 to +5.25	VDC
+5 Digital	13	12	J2	+4.8 to +5.25	VDC
Vres#	14	12	J2	+2.7 to +5.25	VDC
+12 Analog	15	18	J2	+11.4 to +12.6	VDC
+VU	16	10	J2	+8 to +11	VDC
-12 Analog	17	18	J2	-11.4 to -12.6	VDC
+5 Display	24	23	J3	+4.8 to +5.25	VDC
Vbb	25	23	J3	+45 to +55	VDC
+12 Analog	26	23	J3	+11.4 to +12.6	VDC
Filament	27	28	J3	+8.5 to +11	VAC rms
Display Offset	27	23	J3	+8 to +11	VDC
+5 Digital	19	20	J4	+4.8 to +5.25	VDC
+12 Analog	22	21	J4	+11.4 to +12.6	VDC

Table 2.1: Voltage Ranges

2.4 Testing the Power Supply unloaded

If the power supply readings exceed the indicated tolerance (particularly the +5 Digital line btween terminals 12 and 13) it is possible that a defective component on the main board is drawing the power supply down. In this case you should test the power supply unloaded before proceeding. To do so, follow this procedure:

Turn the unit off and remove the three connectors on the right side of the power supply, leaving only the connector from the transformer attached. Voltages should read as in the chart above. If these readings are normal when the supply is unloaded, then a problem with the main or keypad/display board is usually indicated.

2.5 Display Self Test Mode

When the keypad/display is receiving power from the pwoer supply but is not in proper communication with hte main board the SQ80 enters self-test mode. In this mode, the display remains blank until you press the buttons on the front panel. Pressing various front panel buttons will cause the display to print characters, underscore characters, clear the screen, etc. The following chart details how the front panel buttons are mapped in self-test mode:

Press	Display reads
SEQ	9.
CART A	Down arrow
<i>Continued on next page...</i>	

<i>...continued from previous page</i>	
Press	Display reads
CART B	Space
Internal	*
BANK 1	?
BANK 2	i
BANK 3	ˆ
BANK 4	Up Arrow
ENV 2	(Advance Cursor)
Compare	7.
Up/Inc.	0
Down/Dec.	1
Write	2
Soft Button #1	3
Soft Button #2	4
Soft Button #3	5
Soft Button #4	6
Soft Button #5	(Enter Flashing Underscore Mode)
Soft Button #6	7
Soft Button #7	8
Soft Button #8	9
Soft Button #9	(Enter Flashing Mode)
Soft Button #10	(Enter Normal Mode)
LFO 1	(Enter Underscore Mode)
LFO 2	8.
LFO 3	+
Master	(Backup Cursor)
Create/Erase	(Clear Screen)
Tracks Select	(Clear Line 1)
Record	(Clear Line 2)
Storage	(Underscore at Cursor)
EDIT	(Underscore at Cursor and adv. Cursor)
Tracks Mix	(Erase Underscore at Cursor)
Tracks Mix	(Erase Underscore at Cursor)
Stop	(Erase Underscore at Cursor and adv. Cursor)
MIDI	(Underscore 5 Characters)
Control	(Underscore 6 Characters)
Locate	(Underscore 7 Characters)
Play	(Underscore 8 Characters)
OSC 1	(Erase Underscore 5 Characters)
OSC 2	(Erase Underscore 6 Characters)
OSC 3	(Erase Underscore 6 Characters)
ENV 1	(Erase Underscore 7 Characters)
DCA 1	\$
DCA 2	,
DCA 3	=

Continued on next page...

<i>...continued from previous page</i>	
Press	Display reads
Filter	Space
ENV 3	Space
ENV 4	Space
DCA 4	Space
MODES	Space
Split/Layer	Space

Table 2.2: Self Test Mode

2.6 Using Self-Test Mode to Diagnose Keypad/Display Assembly

1. If the unit comes in with a blank display, but is in self-test mode (i.e. the display prints out characters when front panel buttons are pressed in accordance with the above chart) this indicates the problem is either the main board or the communication link between the main board, keyboard and the keypad/display board. Before replacing anything, check all connections, particularly the four (4) wire connector to the keypad/display board. Test the main board with a known good keypad/display board to determine whether the main board or keypad/display board is at fault. If the main board is at fault, try re-initializing the unit as outlined in step 14 of the SQ80 test procedure (page 23, also see flow chart on page 12).
2. If the display is blank and remains blank (not in self-test mode) turn the unit off, open the front panel, and disconnect the four-wire connector from the keypad/display board. This interrupts communications between the main board and the keypad/display board. Close the lid and turn the power on. If the unit now enters the self-test mode, this indicates a main board or keyboard problem. If removing the four-wire connector from the keypad/display board does not activate the self-test mode (assuming all power supply voltages checked out properly), this indicates a faulty keypad/display board.
3. If the unit is in self-test mode but the display does not respnd according to the above chart, the problem is most likely in the keypad/display board. If certain buttons do not function properly during normal SQ80 operation, test them while the unit is in self-test mode. If the same buttons do function properly in self-test mode, then the problem is most likely scrambled software (the unit will need to be re-initialized as outlined in step 14 of the SQ80 test procedure).
4. If the sign-on message appears but the SQ80 doesn't respond to button presses, try re-initializing the unit as described in step 14G of the test procedure. If this doesn't correct the problem, the keyboard is most likely at fault.

2.7 SQ80 Test Procedure

The following procedure will ensure the thorough testing of the SQ80 and will give aid in troubleshooting the unit. To perform the following tests you will need a cassette tape deck, a short MIDI cable, a foot switch, a control voltage (CV) pedal and an EEPROM storage cartridge. The SQ80 should be connected in stereo to a sound system.

The SQ80 is heavily software dependent, and certain events can cause the unit to glitch and contract a severe case of amnesia. Sometimes these units merely require re-initialization (see page 23, step 14). Since scrambled software can cause problems that at first glance appear to be hardware-related, the use of correlation modules, particularly a known-good keypad/display board, is strongly recommended.

If the keypad/display board is unknown, it can cause confusion in tracking down the problem. If you do not have known-good correlation modules and suspect a keypad/display problem, you should test this module first (see "Using self test mode", page 18).

1. Memory Retention Test

- (a) While holding the **RECORD** button, press the **MASTER** button. The sign-on message should appear. Create a short sequence (see page 111 of the SQ80 Musician's Manual) and keep it.
- (b) Flip the power switch off and on 5 times, allowing the sign-on screen to be displayed each time.
- (c) Press the **INTERNAL** button.
- (d) Select each bank and verify that program names are not scrambled.
- (e) While in each bank, select any program using the soft buttons and play it to verify that the sound is not scrambled.
- (f) Press the **SEQ** button, select the sequence you created using the appropriate soft-button.
- (g) Press the **CONTROL** button, select **COUNTOFF** and set it to **CLICK**.
- (h) Press **PLAY** and listen for the metronome countoff click.
- (i) Allow the sequence to play for a short time to verify that the sequence data is not scrambled.
- (j) Press **STOP/CONT** to stop the sequence.

Failure to retain internal programs and sequences may require the addition of a ferrite bead (see Appendix K). If the unit already has a ferrite bead, failure indicates a main board problem. Failure to hear the metronome indicates a main board problem.

2. Memory Backup Test

- (a) Select the sequence that was created above. Turn the unit off.
- (b) Wait 10 seconds.

- (c) Turn the unit on. Verify that the sequence is retained.

Failure to retain internal programs may require the addition of a ferrite bead (see Appendix K). If the unit already has a ferrite bead, failure indicates a main board problem. *[A really big problem: Get a 3.6V solder-in battery and replace the SQ80's internal battery.]*

3. Analog Input Test

- (a) While holding down the RECORD button, press the COMPARE button.
- (b) Repeatedly press the *READ* soft-button and verify each of the following:
 - 1 PTCH reads
 - a between 110 and 150 when the pitch wheel is centered
 - b 30 or lower when pitch wheel is down
 - c 220 or higher when pitch wheel is up
 - 2 MOD reads
 - a 0 when the mod wheel is down
 - b at least 240 when wheel is up
 - 3 KNOB moves from 0 to 255 when the data entry slider is moved.
 - 4 PED moves from 0 to 255 when the pedal is moved.
 - 5 BAT reads 0
- (c) Make sure the pitch wheel is not being held off-center and press *READ* one more time.

Failure on this page indicates a problem with the corresponding part, although it could also indicate a power supply failure or a main board problem. If *all* the readings are off, then it is most likely that there is a problem with the main board.

4. Sustain Jack Test

Plug the foot switch into the Sustain Ft. Sw. jack and verify that notes sustain when the switch is depressed and follow their normal decay when it is released.

Failure indicates a main board problem or a poly-pressure keyboard problem.

- 5. **Sequencer Jack Test** Plug the foot switch in to the Sequencer Ft. Sw. jack and verify that you can start and stop the sequencer with alternate depressions of the switch.

Failure indicates a main board problem or a poly-pressure keyboard problem.

6. Cartridge Test

- (a) Insert an EEPROM storage cartridge into the Program Cartridge slot.
- (b) Press the CART A button and verify that all four banks can be selected and that none of the names are garbled.

- (c) Repeat step (b) for CART B
- (d) Press the WRITE button, and then select the soft-button above *YES*.
- (e) Select a location in memory to store the selected program.
- (f) The display should respond WRITING NEW PROGRAM... and return to normal with no error after approx. 4 seconds. Check all cartridge banks and pages for correct name data.
- (g) Remove the cartridge.

Failure usually indicates a main board problem. Check the cartridge cable however, to see that it is installed correctly (stripe at pin 1) and that none of the connectors' pins are offset or bent under.

Note: In some cases, a defective main board can garble the contents of the storage cartridge. If this happens, reload it from a known-good SQ80 by copying the data from a good cartridge over the garbled data. See the SQ80 Musician's Manual for details.

7. Keypad Test

- (a) After pressing INTERNAL, press each soft-button to verify that the appropriate program name gets underlined.
- (b) Press each button in the VOICE section and verify that they select the proper pages. (The name on each page, which corresponds to the button pressed, appears in the upper-left corner of the display.)
- (c) Test the sequencer transport controls (RECORD, START/STOP and PLAY) to verify the proper operation.
- (d) When on the Locate page, press the up arrow key. The tempo should increase. Press the down arrow key. The tempo should decrease.

Failure most likely indicates a problem with the keypad/display board. Main board and keyboard problems, however, also affect the keypad function.

8. Stereo Test

- (a) Press the DCA4 button and select PAN.
- (b) Using the data entry slider, move the pan value to 0 and play more than 8 notes. There should only be sound coming from the left channel.
- (c) Move the pan value to 15 and play more than 8 notes. There should only be sound coming from the right channel.
- (d) Unplug the left output and play notes while moving the pan value up and down. There should only be sound coming from the right channel and adjusting the pan setting should have no effect.

Failure indicates a main board problem.

9. Tape Output Test

Note: The tape interface on the SQ80 is very level-sensitive. We recommend that a good quality tape deck with variable output control be used, and that levels be set at 0 dB for best results. Also, be sure to switch off any noise reduction (see Hardware Notes on page 25).

- (a) Connect the Tape Out jack to the input of the tape deck.
- (b) Rewind the tape.
- (c) Press the **STORAGE** button and select **TAPE**, then **SAVE**.
- (d) Start the tape deck recording and then select **INT BANKS**. If no level shows on the tape deck meters, check your connections and level settings. If any signal is recorded on the tape, it is safe to assume that the tape output is working correctly.
- (e) After 50 seconds, the display should return to normal.
- (f) Rewind the tape.

Failure usually indicates a main board problem.

10. Tape Input Test

- (a) Connect the Tape In jack to the output of the tape deck.
- (b) While holding down the **RECORD** button, press soft-button #1.
- (c) Answer ***YES*** to re-initialize the system (see Re-Initialization of Unit, step 14)
- (d) Press the **STORAGE** button, and select **TAPE** then **LOAD**.
- (e) Start tape playback and, after the leader tone appears on the tape deck's level meters, select **INT BANKS**.
- (f) After approx. 50 seconds, the display should return to normal without error.
- (g) Press the **INTERNAL** button and select each bank to verify the program names have not been scrambled.

If the tape input on the main board is not functional, the message **TAPE NOT STARTED ON LEADER** will always appear. If the tape loads for a while and then the display reports **FATAL ERRORS DETECTED**, it is highly unlikely that there is a problem with the main board. It is much more likely that the tape level is not set properly. See Tape Tips, Hardware Notes page 25.

11. Filter Tune

- (a) While holding the **RECORD** button, press the **FILTER** button.
- (b) The value for each filter will be displayed sequentially. Verify that all numbers are above 140.

Failure indicates a main board problem.

12. Sound Test

- (a) Select your favourite patch with velocity and pressure sensitivity and play.

- (b) Play all of the keyboard keys and check for velocity sensitivity and pressure.
- (c) Adjust the volume slider to make sure it has the appropriate effect on volume.

Failure usually indicates a main board or volume slider problem. A consistently dead key would indicate a keyboard problem.

13. MIDI Test

- (a) Connect MIDI in to MIDI out with a MIDI cable.
- (b) Hold down a few keys.
- (c) Disconnect one end of the MIDI cable.
- (d) When you release the keys, the notes should sustain.
- (e) Play eight or more keys simultaneously to re-initialize the voices.

Failure indicates a main board problem.

14. Re-Initialization of Unit

The following procedure is not a normal part of the test, and should only be performed in the event that the software becomes scrambled or if indicated as part of another procedure in this manual.

Warning: All sounds and sequences will be lost in the re-initialization process. Save any important data before re-initializing.

- (a) While holding the RECORD button, press soft-button #1.
- (b) Display should read ERASE ALL MEMORY AND RE-INITIALIZE.
- (c) Select *YES*.
- (d) The display will return to the sign-on message. All RAM is erased and all internal programs reset.

Note: When re-initializing, the forty factory sounds will automatically be loaded into memory.

- (e) Tune the filters (see step 11).
- (f) If you are unable to re-initialize the unit due to scrambled software (i.e. the keypad not responding), you can clear the RAM by following procedure.
 - i. Make sure the power is off!
 - ii. Short the *lower* lead of R1 to the *bottom left pin* (pin 28) of U50.

You should now be able to re-initialize the unit as described above.

2.8 Hardware Notes

1. Display Problems

Units with serial numbers less than 500210 have a higher chance of having their glass fluorescent display broken during transport. If the display is found to be defective, be careful when removing it. When changing the display on one of these units, use an exacto knife to route out the lid in the area shown to ensure that the new glass fluorescent display doesn't contact the plastic control panel:

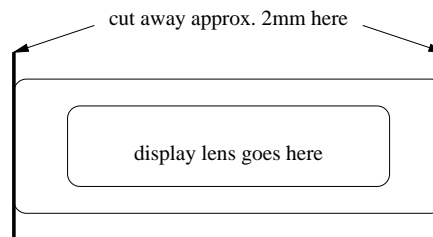

Figure 2.3: Underside of Control Panel

2. Keyboard Problems

Units with serial numbers less than 500270 may show the following problems more frequently:

- consistently failing calibration
- stuck on the Calibrating Keyboard page
- not responding to button presses
- individual keys not working
- notes hanging

These symptoms most likely indicate a keyboard failure. The keyboard should be replaced.

3. Double Button Presses

In some units there have been problems selecting certain program positions. This problem shows up either when holding down `BANK 1` and soft button #10, or when holding down `CART A` and soft button #7. Swapping the keypad/display board should fix the problem. If the customer doesn't want the keypad/display board swapped, the work-around is as follows:

- `BANK 1` and soft-button #10
Press `BANK 1`, then hold down `INTERNAL` and press soft-button #10.
- `CART A` and soft-button #7
Press `CART A`, then hold down the proper bank button and press soft button #7.

Three button presses in any order are needed to tell the SQ80 what to select. This work-around just changes the order in which the three buttons are pressed.

4. **Tape Tips**

- When saving data to a home-type deck with level controls and VU meters, make sure the record level is high enough (right near 0dB seems to work best). Too low a record level will bury the data in tape hiss.
- When loading, wait 4 to 6 seconds into the leader tone before pressing the SQ80 button that starts the procedure. This lets the tone "settle out" and lets the recorder get up to speed.
- If the recorder doesn't have a level meter, listen for the leader tone before starting tape load operation.
- When loading from a recorder that has a tone control, make sure it is in the flat position. Lots of treble boost or cut will distort the pulse waveforms on the tape.
- **TAPE NOT STARTED ON LEADER TONE** may mean the level is too low. **FATAL ERRORS DETECTED - ALL INTERNAL MEMORY RESET** may mean the level is too high.

Generally, the correct input level will fall in between the levels which yield the above messages. If you get the **TAPE NOT STARTED ON LEADER TONE** message, and you know that the tape was started on the tone, then the level is too low. If you then increase the level, and get the **FATAL ERRORS DETECTED - ALL INTERNAL PROGRAMS RESET** message, the level is now too high. Try level between the two. (Of course, the above messages may mean just what they say.)

Appendix A

Replacing the Main Board

1. Remove all cables connected to the SQ80, including the power cable.
2. Remove the four screws that fasten the control panel and raise it (see page 11: Important things to know about the SQ80 - Lid inserts).
3. Remove the keyboard and metal main board shield (see Appendix C). Note that you should remove the 20-pin ribbon cable from the main board at J3 instead of from the keyboard.
4. Remove the seven nuts from the rear panel jacks marked *Sustain Ft. Sw.*, *Sequencer Ft. Sw.*, *Tape Out*, *Tape In*, *Pedal/CV*, *Left/Headphones* and *Right Audio Out*.
5. Remove the Program Cartridge cable (J2) from the main board. Remove the seven self tapping screws from the main board and the one ground screw with star washer (see page 10: Important things to know about the SQ80 - Ground wires, ground inserts).
6. Before installing the new circuit board, make sure the cardboard insulator is in place.
7. With the board tilted on a slight angle, insert the jacks into the holes in the rear panel. Press the board down into place.
8. Replace the main board screws and secure the jacks with the nuts. Connect the program cartridge cable and the keyboard cable.
9. Reinstall the keyboard and metal shield (see Appendix C).
10. Power up, test the unit, and close the front panel.

Appendix B

Replacing the Keypad / Display Board

1. Remove all cables connected to the SQ80, including the power cable.
2. Remove the four screws that fasten the control panel and raise it (see page 11: Important things to know about the SQ80 - Lid inserts).
3. Remove the six-wire and four-wire cable harnesses located on the left side of the keypad/display board. Note that they are keyed.
4. The individual coloured buttons are held in place only by the keyboard/display board underlay. To prevent them from falling out when the board is removed, make sure the control panel is open all the way. [*If not, well, I hope you like Puzzle games.*]
5. Remove the 21 screws that hold the keypad/display in place and carefully remove the keypad/display. Remove the cardboard insulator (if present) that covers the bottom of the keypad/display board.
6. To reassemble, first make sure that the Insulator and all the buttons are in place. Make sure that the eight display lens retainers are in the proper position and that the lens is clean.
7. Install the new keypad/display board with the cardboard insulator (if present) using the 21 screws. Reconnect the wire harnesses paying attention to polarity. Reinstall the knobs on the data entry and volume sliders.
8. Power up, test the unit, and close the front panel.

Appendix C

Replacing the Keyboard

1. Remove all cables connected to the SQ80, including the power cable.
2. Remove the four screws that fasten the control panel and raise it (see page 11: Important things to know about the SQ80 - Lid inserts).
3. Disconnect the keypad/display cable (J4), the power cable (J11), and the pitch/modulation wheel cable (J12) from the main board. If a metal main board shield is present, remove the six screws that fasten it to the case and keyboard frame. Remove the metal shielding from the unit. (See page 10: Important things to know about the SQ80 - Main Boards and Shields).
4. Place the unit upside down on a soft surface and remove the ten screws that attach the keyboard to the case. See figure I for location of screws.
5. Carefully turn the unit right side up. Raise the control panel and disconnect the keyboard ribbon cable (J3) from the main board, paying particular attention to its polarity.
6. Remove the keyboard from the case by gently lifting up the front of it while pulling it toward the front of the unit. Once the rear of the keyboard has cleared the control panel mounting tabs, the keyboard can be removed from the keyboard cavity. (See page 7: Important things to know about the SQ80 - The keyboard.)
7. Making note of the proper polarity, remove the keyboard ribbon cable from the old keyboard and install it on the new one.
8. Connect the keyboard ribbon cable to the main board. Be sure that the cable lies beneath the keyboard and is not pinched under the keyboard frame.
If the ribbon cable is mis-pinned, fuses F3 and F4 will be blown.
9. Insert the new keyboard rear first into the unit at the front of the keyboard cavity. Gently slide the keyboard toward the rear of the unit, lowering the front of the keyboard needed to clear the control panel mounting tabs.
Make sure the disk drive ribbon cable is not caught underneath the keyboard standoff.

10. Turn the unit upside down on a soft surface and replace the ten screws that secure the keyboard in the case.
11. Install the metal shield over the main board (of present) and replace the six screws that fasten it to the case and keyboard frame. (See page 10: Important things to know about the SQ80 - Main Boards and Shields).
12. Connect the keypad/display cable, power cable, and pitch/mod wheel cable to the main board.
13. Power up, test the unit, and close the control panel.

Appendix D

Replacing the Power Supply

1. Remove all cables connected to the SQ80, including the power cable.
2. Remove the four screws that fasten the control panel and raise it (see page 11: Important things to know about the SQ80 - Lid inserts).
3. Disconnect pin connectors J1, J2, J3 and J4 from the power supply board. Note that these connectors are keyed.
4. Remove the two screws and nuts that secure the power supply to the case. Note that there are lock washers on each screw and a ground wire leading from the line filter to the center screw (remove this wire from the line filter end).
5. Remove the power supply board by pulling the front of the board toward the keyboard and then lifting it up so that the heat sink clears the case.
6. Before replacing the power supply board, first make sure that the insulator pad is in place. The standoffs are intended only for support and should not be stuck down to the case.
7. Reinstall the power supply screws and lock washers and be sure to connect the ground wire from the line filter. Carefully reconnect the three cables, paying particular attention to the alignment of pins and connectors.
8. Power up, test the unit, and close the control panel.

Appendix E

Replacing the Transformer

Due to problems that may occur with the plastic case, all units that need the transformer replaced should be sent back to the Ensoniq office. *[Again, a really useful hint.]*

Appendix F

Replacing the Pitch/Mod Wheel Assembly

The Pitch and Mod Wheels are preplaced as an assembly along with the cable harness.

1. Remove all cables connected to the SQ80, including the power cable.
2. Remove the four screws that fasten the control panel and raise it (see page 11: Important things to know about the SQ80 - Lid inserts).
3. Place the unit upside down on a soft surface and remove the four screws that attach the wheel assembly to the case. See figure I for location of screws.
4. Return the unit to an upright position. Cut the wire ties that hold the wire harness to the chassis. Disconnect the harness from the main board, from the keypad display board and from the power supply. Note that these connectors are keyed and have connector locks. Carefully lift the wheel assembly out of the case.
5. Disconnect the cables from the disk drive, paying particular attention to polarity.
6. Remove the disk drive and place it into the new assembly as described in Appendix J. Reattach the disk drive cables.
7. Connect the new wire harness to the main board (J4, J11, J12), to the keypad/display board (four-pin), and to the power supply (J2, J4), paying particular attention to the alignment of pins and connectors. Reconnect the wire harness to the case.
8. Reattach the wheel assembly to the case using the four screws.
9. Power up, test the unit, and close the control panel.

Appendix G

Replacing the Line Filter

1. Remove all cables connected to the SQ80, including the power cable.
2. Remove the four screws that fasten the control panel and raise it (see page 11: Important things to know about the SQ80 - Lid inserts).
3. Remove the three wire tabs connected to the back of the filter, paying particular attention to polarity.
4. Remove the two screws and nuts that secure the filter to the case. Note that there are lock washers on the inside only.
5. To replace the line filter, first make sure that the foil shield is in place. Install the new line filter from the outside of the case. The foil shield should make contact with the bottom of the new line filter.
6. Reconnect the three wires to the filter, again noting the proper polarity.
Failure to connect the wires to their poer post can lead to a potential shock hazard!
7. Power up, test the unit, and close the front panel.

Appendix H

Replacing the Operating System EPROMs

The SQ80 operation system can be updated by replacing the OS EPROMs. Each SQ80 has *two* operating system EPROMs located in the center of the main board. After replacing these EPROMs, the SQ80 must be re-initialized and the filters must be tuned. The program and sequencer memory are erased during re-initialization, so all data must be saved before starting this procedure.

1. Remove all cables connected to the SQ80, including the power cable.
2. Remove the four screws that fasten the control panel and raise it (see page 11: Important things to know about the SQ80 - Lid inserts).
3. Remove the six screws that fasten the metal main board shield (if present) to the case and keyboard frame. (See page 10: Important things to know about the SQ80 - Main Board and Shields) Disconnect the keypad/display cable (J4), the power cable (J11), and the wheels cable (J12) from the Main Board. Remove the metal shields from the unit.
4. The two operating system EPROMs, U16 (OSHI) and U20 (OSLO), are located in the center of the main board. Carefully remove the two EPROMs and insert the replacement EPROMs into their respective sockets. **Be sure the notch in both EPROMs is facing towards the front of the SQ80.**
5. Power up, re-initialize the system and tune the filters.
6. Check the software version level by holding down RECORD and pressing MASTER.
7. Reinstall the metal main board shield (if present). Test the unit and then close the front panel.

Appendix I

Replacing the Keyboard (KPC) EPROM

1. Remove all cables connected to the SQ80, including the power cable.
2. Remove the four screws that fasten the control panel and raise it (see page 11: Important things to know about the SQ80 - Lid inserts).
3. Remove the six screws that fasten the metal main board shield (if present) to the case and keyboard frame. (See page 10: Important things to know about the SQ80 - Main Board and Shields) Disconnect the keypad/display cable (J4), the power cable (J11), and the wheels cable (J12) from the main board. Remove the metal shield from the unit.
4. Place the unit upside down on a soft surface. Remove the ten screws that attach the keyboard to the case.
5. Carefully turn the unit right side up. Remove the keyboard from the case by gently lifting the front of the keyboard while pulling it toward the front of the unit. Once the rear of the keyboard has cleared the control panel mounting tabs, the keyboard can be turned over.
6. The KPC EPROM is in location U2 of the KPC board (the small PC board on the bottom of the keyboard). Carefully remove the EPROM and insert the replacement EPROM into the socket. **Be sure the notch in the EPROM is facing the same direction as the other chips on the KPC board.**
7. Power up, re-initialize the system and tune the filters. Test the unit to make sure the keyboard is working properly.
8. Turn the unit off and turn it upside down on a soft surface to replace the ten screws that secure the keyboard to the case.
9. Turn the unit right side up. Replace the four screws that attach the metal main board shield (if present) to the keyboard bottom shield. Close the front panel.

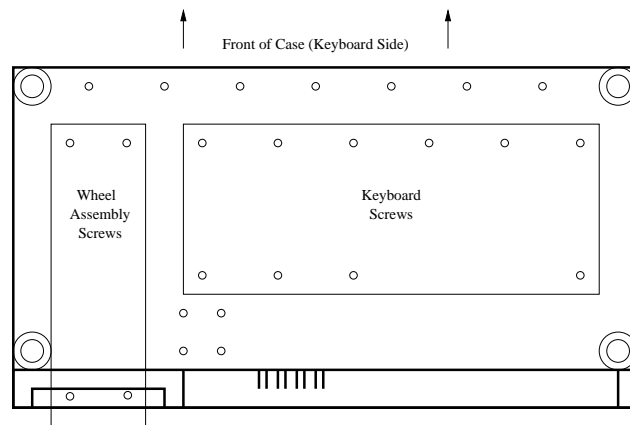

Figure I.1: Bottom of Case

Appendix J

Replacing the Disk Drive

1. Remove all cables connected to the SQ80, including the power cable.
2. Remove the four screws that fasten the control panel and raise it (see page 11: Important things to know about the SQ80 - Lid inserts).
3. Turn the unit over, top down, and remove the four screws that attach the wheel assembly to the case. See figure I for location of screws. Return the unit to an upright position. Carefully lift the wheel assembly out of the case.
4. Disconnect the two cables from the disk drive, paying particular attention to polarity. (See page 8: Important things to know about the SQ80 - The Disk Drive)
5. Remove the four screws and star washers that attach the disk drive to the wheel assembly.
6. Carefully slide the disk drive out of the wheel assembly. Remove the two screws and star washers that attach the metal plate to the bottom of the disk drive.
7. Immediately place defective drive in the anti-static bag that the new drive came in. Attach the metal plate to the new disk drive using the two screws and star washers.
8. Slide the new disk drive into place and mount it using the four screws and star washers. Reconnect the two cables, paying particular attention to the alignment of pins and connectors.
9. Reattach the wheel assembly to the case using the four screws.
10. Power up, test the unit, and close the control panel.

Appendix K

Adding a Ferrite Bead

A ferrite bead should be added to any unit that doesn't retain its internal memory reliably.

1. Remove all cables connected to the SQ80, including the power cable.
2. Remove the four screws that fasten the control panel and raise it (see page 11: Important things to know about the SQ80 - Lid inserts).
3. Carefully surround the nine wires that lead from the transformer to the power supply (J1) with both ferrite bead halves.
4. Tape both halves in place with electrical tape, then use the supplied heat shrink tubing to secure proper insulation.
5. Use a tyrap to keep the ferrite bead as close to the power supply connector (J1) as possible.
6. Test for memory retention as described in the SQ80 test procedure steps 1 and 2 on page 19.
7. Close the front panel.

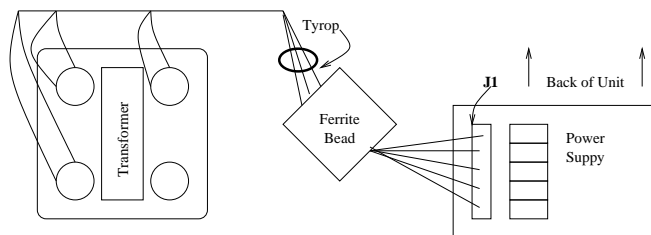

Figure K.1: Ferrite Bead Location